

**WIPERS AND WASHERS**

**Description**

**Headlamp power wash**

The headlamp power wash is actuated when the windscreen washer control is used with headlamp low beam illuminated.

**Washer reservoir**

A combined underhood washer reservoir supplies the windscreen, tailgate glass and headlamp power wash. Three separate supply hoses are used with an electric pump for each facility. The reservoir incorporates a low level warning device.

**NOTE:** See Electrical Section 86 for wiring diagram.

**WASHER RESERVOIR**

**Remove and refit**

**Removing**

1. Loosen the hose-clamp and remove the power wash hose.
2. Disconnect the tubing from the washer pumps.
3. Disconnect the electrical leads from the pumps and the low level warning unit.

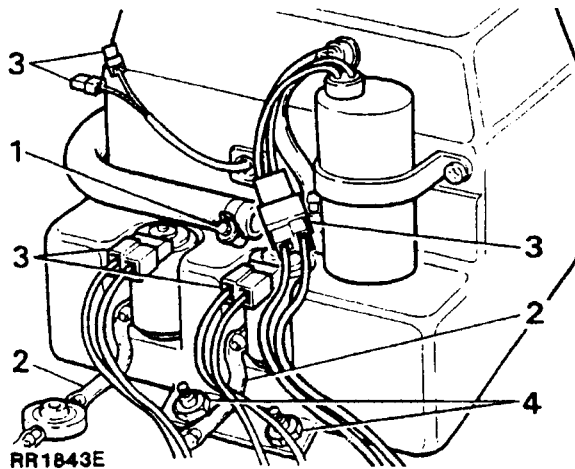

4. Remove the three securing bolts from below and withdraw the reservoir.

**Refitting**

5. Reverse instructions 1 to 4

**POWER WASH PUMP**

**Remove and refit**

**Removing**

1. Disconnect the hose from the power wash pump.
2. Disconnect the electrical leads from the pump.

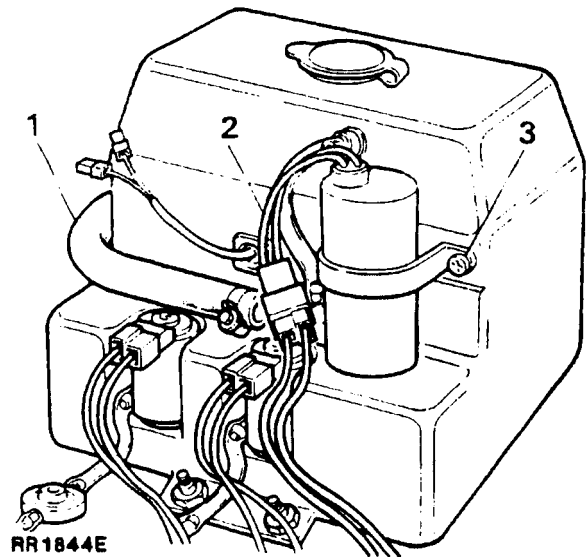

3. Remove two screws and withdraw the power wash pump.

**Refitting**

4. Reverse instructions 1 to 3.

**WINDSCREEN WASHER PUMP**

**TAILGATE GLASS WASHER PUMP**

**Remove and refit**

**Removing**

1. Disconnect the washer tubing from the pump.
2. Disconnect the electrical leads from the pump.

3. Pull the top of the pump away from its location in the reservoir and remove the pump. Note the position of the sealing gasket in the reservoir.

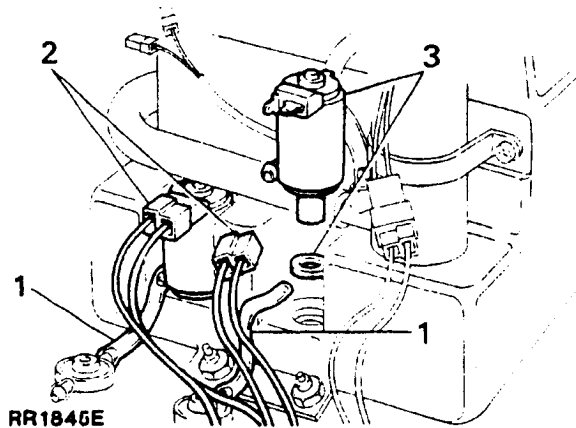

#### Refitting

4. Reverse instructions 1 to 3

#### WINDSCREEN WASHER TUBES

##### Remove and refit

##### Removing

1. Disconnect tubes from the jets.

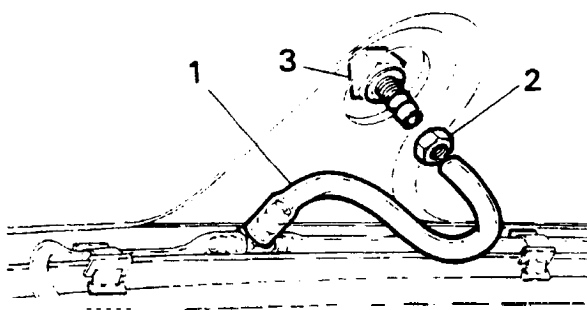

2. Remove the locknut and washer securing jet to hood.
3. Remove jet.

#### Refitting

4. Reverse instructions 1 to 3.

#### WINDSCREEN WASHER TUBES

##### Remove and refit

##### Removing

1. Disconnect tubing from reservoir pump.
2. Disconnect tubing from washer jets.
3. Disconnect tubing from three-way tee piece.
4. Release tubing from edge clips.

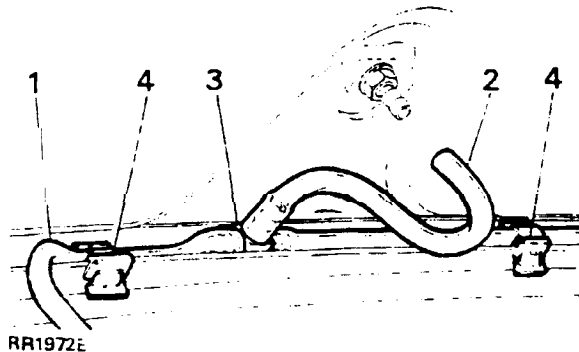

#### Refitting

5. Reverse the removal procedure.

#### WIPER ARMS (WINDSCREEN)

##### Remove and refit

##### Removing

1. Hold back the small spring clip which retains the wiper arm on the shaft boss using a suitable tool.
2. Gently pry off the wiper arm from the shaft boss.

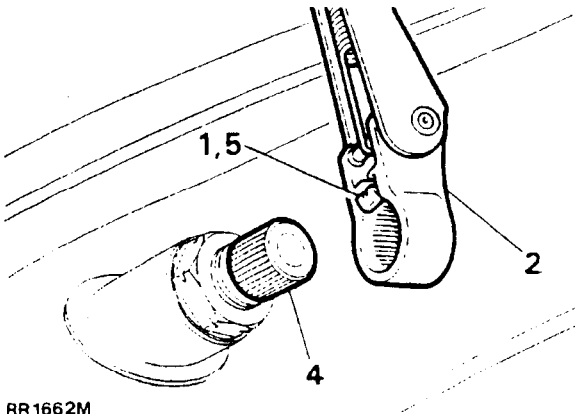

RR1662M

**Refitting**

3. Allow the motor to **move** to the 'park' position.
4. Push the arm on to the **boss**, **locating** it on the splines so that the wiper blades are just clear of the screen rail
5. **Ensure that the spring retaining clip is located in the retaining groove on the shaft boss.**
6. Operate the wiper on a wet screen to ensure that the blade does not over-travel at either end of its stroke.

**WIPER ARM (TAILGATE)**

**Remove and refit**

**Removing**

1. Lift the wiper arm end cap to gain access to the wiper motor shaft.
2. Remove the wiper arm securing nut.

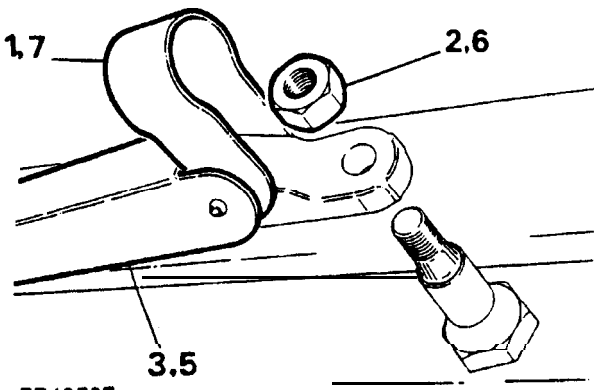

RR1958E

3. Withdraw the wiper arm from the shaft.

**Refitting**

4. Allow the motor to move to the 'park' position.
5. Fit the wiper arm to the **shaft**, **locating** it on the splines so that the wiper blade is just clear of the screen surround.
6. Fit and tighten the securing nut.
7. Push the end cap back into position.
8. Check the correct **operation** of the wiper.

**WIPER BLADES (WINDSCREEN AND TAILGATE)**

**Remove and refit**

**Removing**

1. Pull the wiper arm away from the glass.
2. Lift the spring clip and withdraw the blade from the arm.

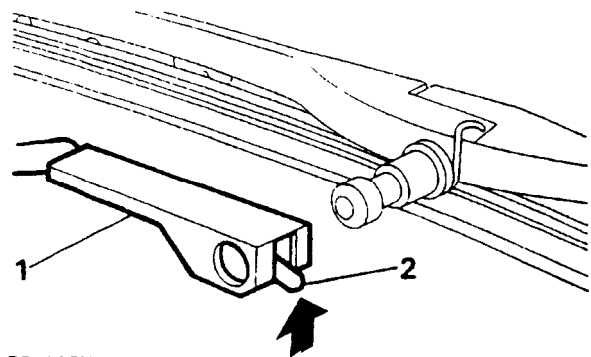

RR1663M

**Refitting**

3. Reverse instructions 1 and 2.

**WINDSCREEN WIPER MOTOR, LINKAGE AND WHEEL BOXES**

**Remove and refit**

**Removing**

1. Disconnect the battery negative lead and remove wiper arms.
2. Remove locknuts from wheel boxes
3. Remove grommet from wheel boxes.

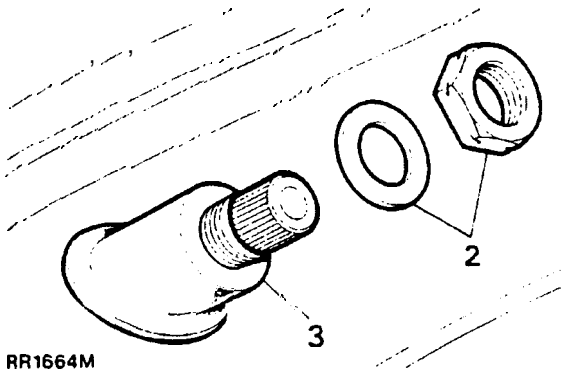

RR1664M

4. Remove hood.
5. Remove front cowl panel.
6. Remove the spring clips securing the primary links to the wheelbox shaft links.
7. Remove the spring clips securing the primary links to the motor crank.
8. Remove the primary links.
9. Remove the lower grommet from the wheelboxes.

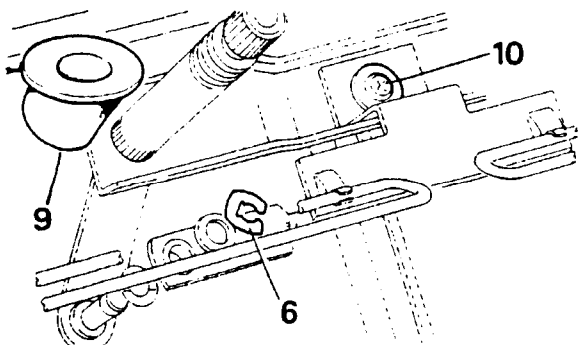

RR1856E

10. Remove the screw securing the hood torsion bar bracket. Unclip the bracket from the torsion bar.

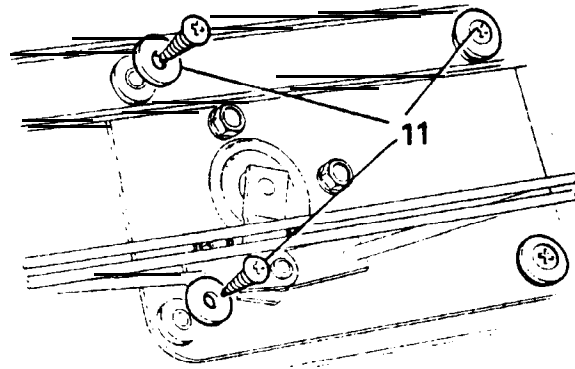

RR1956E

11. Remove the remaining screws securing the motor and linkage assembly to the bulkhead.
12. Gently ease the unit out of its mounting location and disconnect the electrical leads at the plug and socket.
13. Withdraw the unit.
14. Remove the three bolts securing the motor to the mounting plate
15. Separate the motor from the mounting plate by pulling the motor crank through the grommet.

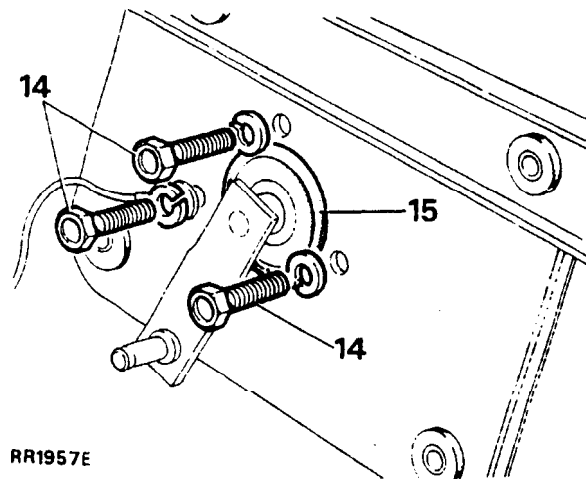

RR1957E

**Refitting**

16. Reverse the removal procedure.
17. When replacing the primary links ensure that they are mounted with the bushes on the inside, that is, towards the wiper motor. The shorter primary link is mounted on the drivers' side.
18. Replace the front cowl panel.
19. Replace the hood.
20. Replace the wiper arms.

**WIPER MOTOR CHECKING**

**NOTE:** These instructions apply to both Windscreen and Tailgate glass wiper motors.

If unsatisfactory operation of the wiping equipment is experienced, a systematic check to determine the origin of the fault should be carried out as follows:

1. Check the blades for signs of excessive friction, as this will greatly reduce the wiping speed of the motor and cause increased current draw which may damage the armature. Check by substitution
2. Check the windscreen wiper motor light running current and speed with the motor coupling link disconnected from the wiper shaft transmission linkage. Check the tailgate glass wiper motor with the wiper connected and the glass wet. Connect a suitable analog or digital ammeter in series with the motor supply and measure the current consumption when the motor is switched on. Check the operating speed by timing the speed of rotation of the motor coupling link. The results should compare with the figures given in 'General Specification Data'.

**NOTE:** If the vehicle wiring connections are disconnected and an alternative supply source is applied it is essential that the correct polarity is observed. Failure to observe this will cause the motor to rotate in the reverse direction, which may result in the limit switch contacts being damaged.

3. If the motor does not run satisfactorily or takes higher than normal current, then a fault is apparent and should be investigated.
4. If the current consumption and speed of the motor are satisfactory, then a check should be carried out for proper functioning of the transmission linkage and wiper arm shafts.

**NOTE:** Service parts are not available for the windscreen and tailgate wiper motors with the exception of the windscreen wiper rotary connecting link. A complete new unit must be fitted in the event of a failure.

**TAILGATE GLASS WASHER JET**

**Remove and refit**

**Removing**

1. Lower or remove the headlining rear section to gain access to the jet securing nut and washer tube connection.
2. Disconnect the washer tube, and remove the grommet. Drain away any water in the tube to avoid damaging the trim.

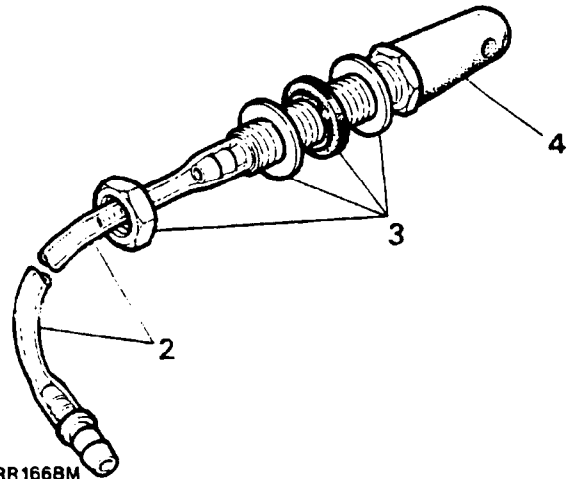

3. Hold the base of the jet and remove the nut and washer.
4. Withdraw the washer jet from outside the vehicle.

**Refitting**

5. Reverse instructions 1 to 4 as appropriate.

## TAILGATE GLASS WIPER MOTOR

## Remove and refit

## Removing

1. Disconnect the battery negative lead.
2. Lower or remove the headlining rear section to gain access to the wiper motor assembly.
3. Remove the wiper arm and blade.
4. Loosen the nut securing the wiper motor to the body. **DO NOT** remove at this stage.

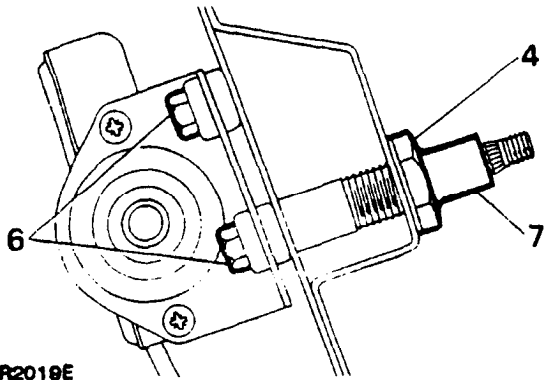

RR2019E

5. Disconnect the electrical leads at the multi-plug.
6. Remove the two bolts securing the wiper motor to the inner body.

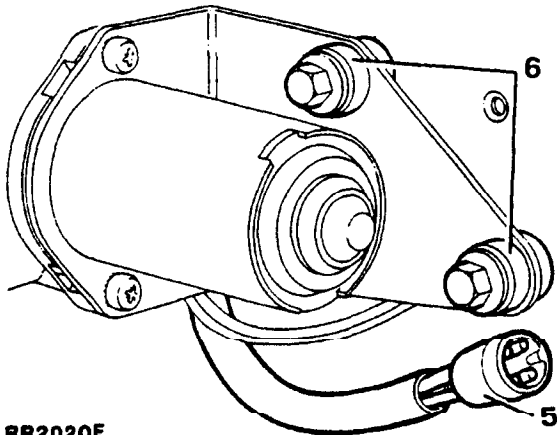

RR2020E

7. Support the wiper motor remove the nut loosened at instruction 4, complete with protective cover, washer and seal. Simultaneously withdraw the wiper motor from the body.

## Refitting

8. Reverse instructions 1 to-7, ensuring that the spacer is correctly positioned before fitting the motor.

## HEADLAMP POWER WASH JET

## Remove and refit

## Removing

1. Disconnect the hose from the power wash jet.
2. Remove the nut securing the jet to the bumper.
3. Remove the power wash jet.

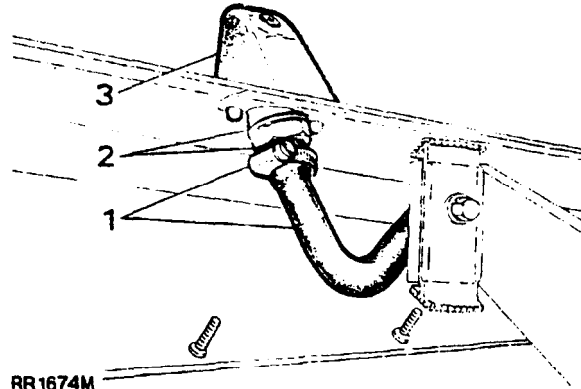

RR1674M

## Refitting

4. Reverse instructions 1 to 3.

## POWER WASH HOSE

## Remove and refit

## Removing

1. Disconnect the hoses from the jets and the washer pump.
2. Release the clamps locating the hose.
3. Remove the power wash hose.

## Refitting

4. Reverse instructions 1 to 3. locating the hose in its original position.

**HEATED WINDSCREEN WASHER JETS**

1989 model year vehicles feature electrically heated windscreen washer jets. The operating thermostat fitted on the righthand headlamp mounting panel senses temperature and will operate the jet heaters at a temperature of  $4^{\circ}\text{C} \pm 3^{\circ}\text{C}$  ( $39^{\circ}\text{F} \pm 5^{\circ}\text{F}$ ).

**Washer jets**

**Remove and refit**

**Removing**

1. Disconnect the battery negative lead.
2. Disconnect the electrical connection at the plug.
3. Withdraw the washer tube from the jet.
4. Push the jet upwards to remove from its mounting.
5. Remove the washer jet mounting from the bonnet, if necessary.

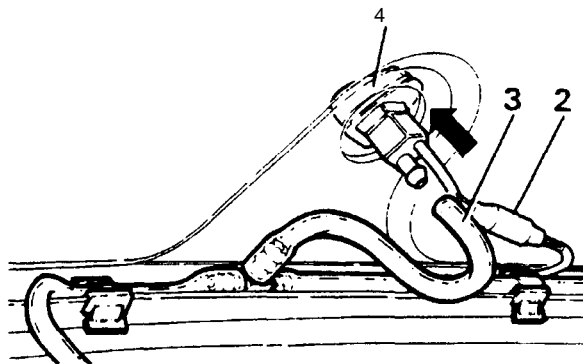

**RR2549M**

**Refitting**

6. Reverse the removal procedure.

**Thermostat**

The thermostat will operate (close) at  $4^{\circ}\text{C} \pm 3^{\circ}\text{C}$  ( $39^{\circ}\text{F} \pm 5^{\circ}\text{F}$ ), and re-open at  $10^{\circ}\text{C} \pm 3^{\circ}\text{C}$  ( $50^{\circ}\text{F} \pm 5^{\circ}\text{F}$ ).

**Remove**

1. Disconnect the battery, negative lead.
2. Remove the radiator grill.
3. Remove two screws securing the thermostat to the right hand headlamp mounting panel.
4. Withdraw the thermostat, disconnecting the electrical connector.

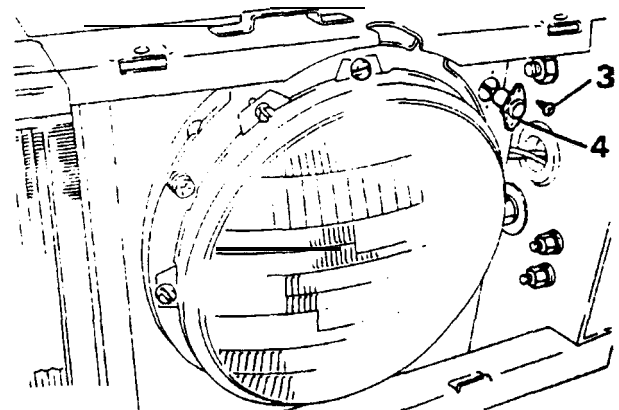

**RR2550M**

**Refitting**

5. Reverse the removal procedure.

1000

1000

1000

1000

1000

1000